

Foratrice multitesta

Multiple boring machine/Perceuse avec plusieurs têtes/Taladro multiple

- Foratrice multitesta con caricamento automatico, pannello passante con 2 teste orizzontali e 5 verticali, ideale per produzioni industriali.
- Automatic through-feed multi head boring machine, with n.2 horizontal head units and 5 vertical head units, suited for high production volumes.
- Perceuses avec plusieurs têtes, chargement automatique, panneau passant avec 2 têtes horizontales et 5 têtes verticales, étudiée pour des productions industrielles.
- Taladros multi cabezales alimentación automática. Panel pasante con dos cabezales horizontales y 5 verticales, solución ideal para producción industrial.

Boring System 240 5V Plus



- Esempi di lavorazione
- Working examples
- Exemples de travail
- Ejemplos de trabajo



Dettagli Details/Détails/Detailles



- **PRESSORI GIREVOLI ANTINFORTUNISTICI**
Gruppo pressori antinfortunistici brevettati, il loro scorrimento su guide lineari a ricircolo di sfere garantisce la massima rapidità di posizionamento.
- **PATENTED TURNING SAFETY CLAMPS**
Patented safety clamp unit, sliding on linear rolling guides for a quick positioning.
- **PRESSEURS PIVOTANTS POUR LA PREVENTION DES ACCIDENTS DU TRAVAIL**
Groupe presseurs brevetés contre les accidents du travail avec glissement sur guides prismatiques qui assurent la rapidité maximum de mise à point de la machine.
- **PRESORES GIRATORIOS ANTIACCIDENTES**
Grupo presores patentados antiaccidentes con desplazamiento sobre guías lineares y patin de recirculación de cojinetes de bolas para garantizar máxima velocidad de posicionamiento.



- **PANNELLO DI CONTROLLO TOUCH SCREEN**
Le principali funzionalità della macchina sono gestite in maniera semi-automatica grazie ad un PLC.
- **CONTROL PANEL TOUCH SCREEN**
Semi automatic management of the main machine functions by a PLC.
- **PANNEAU DE COMMANDE TOUCH SCREEN**
La machine est équipée d'un PLC qui permet le réglage de la machine en manière semi-automatique.
- **CUADRO DE MANDOS TOUCH SCREEN**
Las funciones mas importantes de la maquina tienen una gestión semi automática mediante un PLC.



- **COMANDI E REGOLAZIONI**
Comandi ergonomici studiati per facilitare l'operatore nella rapida messa a punto della macchina. La profondità di foratura viene impostata tramite contatore numerico, con tabella di riferimento alla lunghezza delle punte.
- **DRIVES AND ADJUSTMENT DEVICES**
The ergonomic drives make it easier for the operator to set up the machine. Boring depth can be quickly and easily adjusted by means of a digital counter, according to the drills length, immediately find out thanks to a reference table on the machine.
- **COMMANDES ET REGLAGES**
Commandes ergonomiques qui assurent la rapidité maximum de mise à point de la machine. Réglage de la profondeur de perçage par compteur digital faisant référence à la longueur des mèches.
- **MANDOS Y DISPOSITIVOS DE REGULACION**
Mandos electricos ergonómicos estudiados para facilitar la puesta a punto de la maquina. Regulación de la profundidad de taladrado mediante contador digital con tablilla de referencia de las tipologias de brocas utilizadas.

- **CARICATORE**
Sistema semi-automatico per il carico e lo scarico dei pezzi, che agevola l'operatore nell'esecuzione del lavoro e permette l'utilizzo della macchina anche come componente di una linea di produzione. Il carico e scarico dei pannelli può essere a ciclo continuo o solo anteriore verso l'operatore.
- **LOADING DEVICE**
Semi automatic device for easy up and down loading of the working panels. This system can work one side of the machine, towards the operator, or both sides of the machine in a continuous-working cycle, which makes this machine also suitable for a production line.

- **SYSTEME DE CHARGEMENT DES PANNEAUX**
Systeme semi-automatique pour charger et décharger les panneaux qui permet de faciliter le travail de l'operateur et aussi d'utiliser la machine dans une ligne de production. Chargement et déchargement des panneaux par cycle continu ou antérieur vers l'operateur.
- **CARGADOR**
Dispositivo semiautomático de carga y descarga de los paneles para agilizar el trabajo del operador y permitir el empleo de la maquina también en una línea de producción. Funcionamiento de ciclo continuo o en dirección del operador.

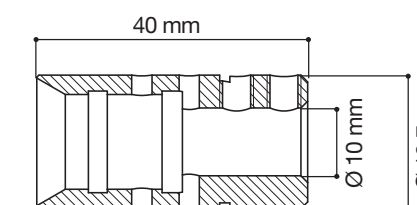

36000061

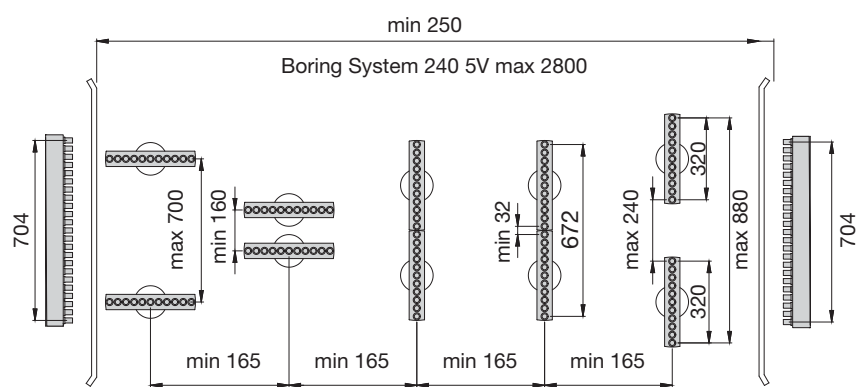

mm 32

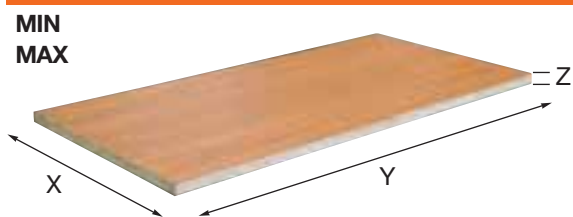
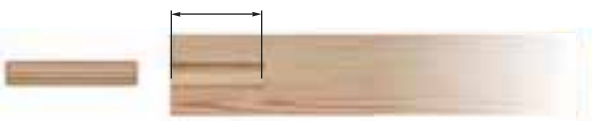

Boring System 240 5V Plus

N 2 Orizzontale / Horizontal
N 10 Verticale / Vertical

32 mm

N 2 Orizzontale / Horizontal
N 23 (N 11 + N 12)

N 10 Verticale / Vertical
N 11 (N 5 + N 6)

55 mm

65 mm

X 150/870mm
Y 250/2800 mm
Z 12/50 mm

HP 2 - kW15
RPM 2800

Boring System 240 5V Plus

N 12

N 10



57 m / min

BAR 6 - 8 / MPA 0,6-0,8
L 60 / CICLO - CYCLE

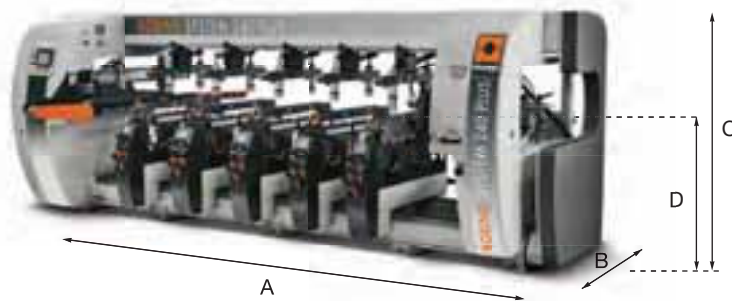

A 4150 mm
B 1600 mm
C 1800 mm
D 950 mm



4300 x 1950 x 1900 H mm
2900 / 3100 kg